



# SMARTVIDE 5 230/50-60/1

Maximum capacity: 30 lt./ 8 gal.



1180101



## FEATURES AND BENEFITS

**Portable precision cooker with stirrer for up to 30 lt. / 8 gal. containers. Designed for chefs, developed with chefs.**

- ✓ The thick stainless steel, robust construction guarantees commercial performance. The front panel and the grip are made of fiberglass-reinforced polyamide.
- ✓ SmartVide guarantees cooking at a **precisely controlled temperature** while preserving the quality of the product, enhancing flavor and texture. Equipped with a highly precise temperature control system to obtain extremely consistent results.
- ✓ Allows cooking food in their own juice and using this juice immediately after cooking to **enhance flavors**.
- ✓ Marinates and macerates an ingredient in **half the time**.
- ✓ **Infuses and flavors** oil, fat or other products applying the controlled temperature technique.
- ✓ Increases **profits** due to lack of product shrink.
- ✓ Requires **very little hands-on time**, allowing the Chef to do other tasks while the product is being cooked. Just program temperature and time, SmartVide will do the rest. 4 buttons and a full-color TFT display that offers **all the information at a glance** makes operation a child's play.
- ✓ SmartVide5 is **portable**: thanks to their ergonomic handle, SmartVide5 can be taken from a container to another easily. Additionally, the optional bag allows easy transport - wherever the Chef goes.
- ✓ **HACCP-ready**: thanks to Bluetooth connectivity, it is possible to export or print cooking results at the end of each cycle.
- ✓ **Your appliance, always updated**: free firmware update, no matter where the appliance is.

## SALES DESCRIPTION

Commercial high-precision sous-vide cooker. Reliable, user-friendly, portable.

Interchangeable between °C and °F.

- ✓ Bluetooth connectivity.
- ✓ HACCP-ready.
- ✓ Optional core probe.
- ✓ Firmware update.

## ACCESSORIES

- Needle Probe for sous-vide cookers
- SmartVide transport bag
- Probe Foam Seal
- Insulated tank for SmartVide immersion circulator
- Lid for SmartVide
- Floating balls for SmartVide



**www.sammic.co.uk**  
 Food Service Equipment Manufacturer  
 Unit 2, Trevanah Road  
 Troon Industrial Park  
 LE4 9LS - Leicester  
 uksales@sammic.com  
 Tel.: +44 0116 246 1900



Project	Date
Item	Qty
Approved	

FOOD PRESERVATION AND SOUS-VIDE  
SOUS-VIDE COOKERS

product sheet  
updated 26/11/2019



# SMARTVIDE 5 230/50-60/1

Maximum capacity: 30 lt./ 8 gal.



1180101

## SPECIFICATIONS

### Temperature

Display precision: 0.01 °C

Range: 5 °C - 95 °C

Permissible ambient temperature: 5 °C - 40 °C

### Time

Resolution: 1 '

Cycle duration: 1 ' - 99 h

### General features

Maximum recipient capacity: 30 l

Total loading: 1600 W

Electrical supply: 230 V / 50-60 Hz / 1 ~

Submergible part dimensions: 116 mm x 94 mm x 147 mm

External dimensions (WxDxH): 116 mm x 128 mm x 330 mm

Net weight: 3.1 Kg

### Crated dimensions

410 x 185 x 285 mm

Gross weight: 5 Kg.

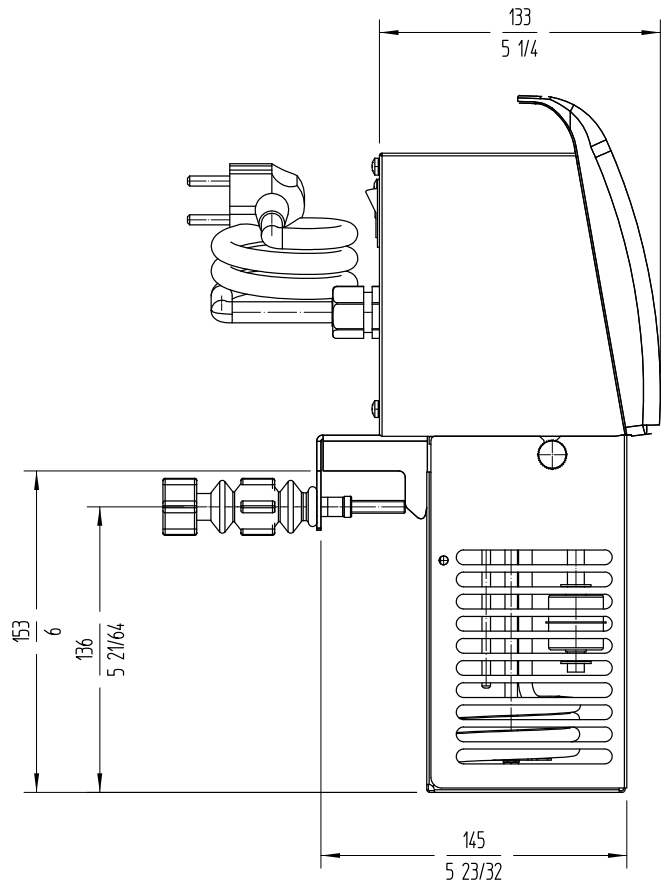
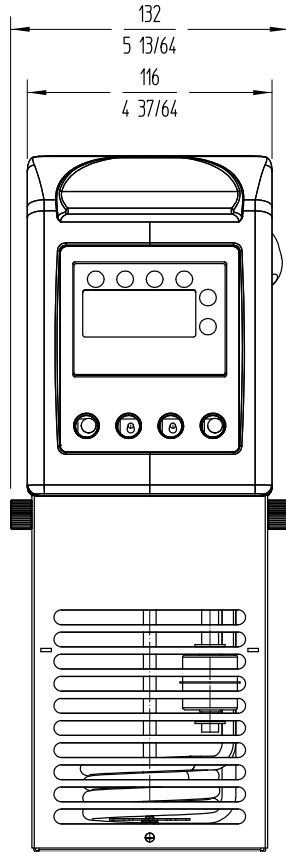

FOOD PRESERVATION AND SOUS-VIDE  
SOUS-VIDE COOKERS



[www.sammic.co.uk](http://www.sammic.co.uk)

Food Service Equipment Manufacturer

Unit 2, Trevanah Road  
Troon Industrial Park  
LE4 9LS - Leicester

[uksales@sammic.com](mailto:uksales@sammic.com)  
Tel.: +44 0116 246 1900



Project

Date

Item

Qty

Approved

product sheet  
updated 26/11/2019