



DOMINATOR**PLUS**

E3917i Solid Top Induction Range



Key features

- 5 zone energy efficient induction hob
 - All the usability, versatility and power of a gas solid top combined with the energy efficiency, increased controllability, easy clean and safety of induction.
 - 7.5kW 320 x 320mm central zone
 - 2 x 3kW 160 x 320mm zones right and left
 - 5kW front and 3kW rear zones are 670 x 100mm
- In-built pan detection
 - No heat generated until a pan is placed on the hob, meaning no wasted energy
- Ideal for multi-pot and large pot cooking
 - Smaller pots can share zones while larger ones can straddle zones
- Heavy duty ceramic glass hob
 - Robust and spillages simply wipe clean, no scrubbing required
- Temperature is precisely controllable
 - Change from gentle simmer to rolling boil almost instantly
- Low cooking surface temperature and no naked flames
 - Safer for kitchen staff as reduced risk of burns
- Very little heat emitted into kitchen
 - Contributes to a more pleasant working environment and existing ventilation doesn't have to work as hard

- 1/1 GN fan-assisted oven
 - 5 shelf positions with 2 shelves supplied
- Wide oven temperature range of 100 - 250°C
 - Ideal to prepare a wide variety of food
- Twin oven doors with glass panels
 - Monitor cooking progress without losing heat

Accessories

- Oven shelf
- Factory fitted, adjustable castors
- Fixed installation kit

Similar Models

- E3907i solid top induction boiling top
- E3914i 4 x 5kW induction range
- E3913i 4 x 3.5kW induction range
- i91105 4 x 5kW induction range (GP oven)
- i91105C 4 x 5kW induction range (fan-assisted oven)

Solid Top Induction Range

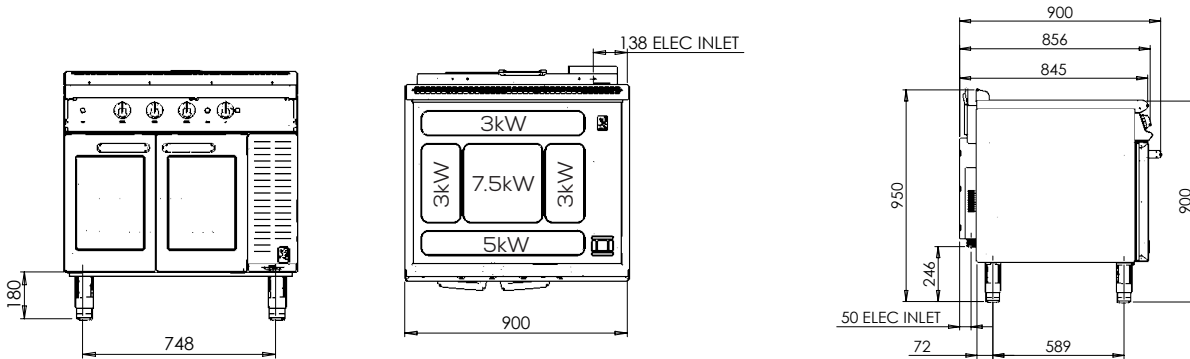

Unit on castors is the same hob height

Measurements *in mm*

Specification details

Electrical rating (kW)	27.5	
Electrical supply voltage	400V 3N~	
Required electrical supply (A)	63A	
Electrical current split (A)	L1: 39.9 L2: 39.9 L3: 39.9	
Element rating - hob (kW)	1 x 7.5, 1 x 5, 3 x 3	
Element rating - oven (kW)	6	
Heat zone sizes (mm)	Centre - 320 x 320	
	Sides - 160 x 320	
	Front & back - 670 x 100	
Minimum pan size (mm)	120	
Oven dimensions (w x d x h - mm)	530 x 535 x 380	
Oven shelf (w x d - mm)	530 x 535	
Gastronorm compatibility	1/1	
Weight (kg)	150	
Packed weight (kg)	165	
Packed dimensions (w x d x h - mm)	1000 x 1000 x 1100	
GTIN numbers	On feet	On castors
	5056466907426	5056466907433

Installation notes

Adequate ventilation must be provided to supply sufficient fresh air for combustion and to allow easy removal of any such products that may present a risk to health. Please consult current legislation for details that relate to specific locations.

Install unit on a level, fireproof surface in a well-lit, draught free position. If floor is made of a combustible material, local fire requirements must be checked to ensure compliance.

A clearance of 150mm should be observed between appliance and any combustible wall.

