

MODEL T36/T36A/T36C

SOFT SERVE FREEZER

SINGLE FLAVOUR, COUNTERTOP, DIGITAL CONTROL



Ideal for **extremely high capacity outlets** to serve ice cream, frozen yogurt, milkshakes or sorbet. Small footprint saves counter space.



FAST FREEZE DOWN

Patented high efficiency heat exchanger allows fast freeze down with low energy consumption



DIGITAL CONTROL AND DISPLAY

Microprocessor control provides access to system settings and additional functions. Digital interface displays critical info as system status, temperatures, dispense count, errors, etc.



AUTO PROGRAMMING

Allows automatic switching of operation modes based on pre-set schedules



STANDBY

Maintains product temperature in both mix hopper and freezing cylinder below 4.4°C (40°F) overnight



HOPPER AGITATOR

Maintain product consistency and prevent product separation



INVERTER SYSTEM

Slow motor start reduces equipment noise and stress on drive



DIRECT DRIVE TRANSMISSION

Eliminates consumable moving parts and increases transmission efficiency



DEFROST FOR CLEANING

Increases efficiency during cleaning by heating frozen product in cylinder



QUICK REFREEZE

Turn on freeze immediately to freeze down to serving viscosity when quick service is required after long idle period



SELF CLOSING VALVE / SPEED CONTROL

Automatically prevents product overflow after dispense; Provides flexibility in dispense rate control

POWERFUL AND VERSATILE SINGLE FLAVOUR EXTREMELY HIGH CAPACITY COUNTERTOP MODEL FOR ICE CREAM, FROZEN YOGURT, SORBET AND MUCH MORE

MAXIMISE YOUR PROFITS

MODEL T36/T36A/T36C

SOFT SERVE FREEZER MACHINE

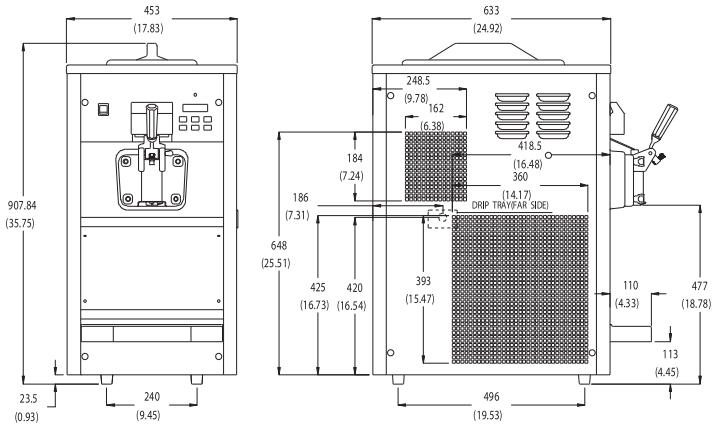

SPECIFICATIONS

Flavours	1	
Freezing Cylinders	1 x 3.2L / 3.4qt	
Mix Hoppers	1 x 12L (10L for A)	
Output Capacity (80 grams)	420 serves/hr	
Clearance Requirements	152mm/6" on left	

WEIGHT	KG/LB (Gravity)	KG/LB (Pump)
Net	139 / 309	144 / 320
Shipping	152 / 338	157 / 349
Volume	0.47 CBM / 16.62 CBF	

DIMENSIONS	NET (MM/IN)	SHIPPING (MM/IN)
Width	453	NA
Depth	678	NA
Height	908	NA

	AMP	VOLT	POWER(KW)
	13	NA	NA

ELECTRICAL T36/A/C Single Phase

FEATURES

CONTROL SYSTEMS	SINGLE DIGITAL
REFRIGERATED HOPPERS	✓
HOPPER AGITATOR OPTIONAL	✓
TEMPERATURE DISPLAY	✓
STANDBY MODE	✓
AUTO CLOSING DISPENSING VALVES	✓
DISPENSING SPEED CONTROL	✓
LOW MIX INDICATOR LIGHT & ALARM	✓
LOW TEMPERATURE PROTECTION	✓
MOTOR OVERLOAD PROTECTION	✓
HIGH PRESSURE PROTECTION	✓
DEFROST & QUICK REFREEZE	✓
SOFT START	✓
DIRECT DRIVE PUMP (A ONLY)	✓
C PUMP AND PASTEURISATION AVAILABLE	✓
21 DAYS CLEANING CYCLE	✓
A PUMP VERSION AVAILABLE	✓

BLUE ICE MACHINES LTD

Lea Road trading Estate, Lea Rd, Waltham Cross, London, Waltham Abbey EN9 1AE

020 8801 6919

info@blueicecreammachine.co.uk
www.blueicecreammachine.co.uk