

O₃ TOWER

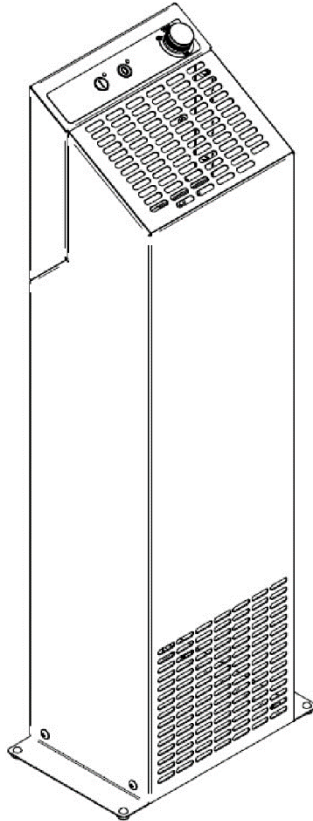

O₃ PORT

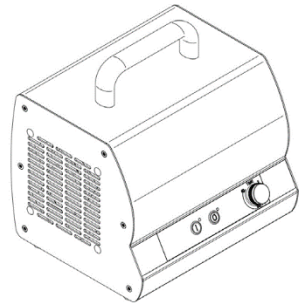

O3 Port-Tower_001 Ed. 06/2020

**USER AND MAINTENANCE
MANUAL**

INTRODUCTION

- *This manual provides the client with information about the machine and applicable regulations, as well as the user and maintenance instructions required to use the machine properly and keep it in good working order.*
- **This manual must be made available to all users and maintenance technicians.**

CONTENTS

PARTE 1 - INFORMATION ABOUT THE MACHINE	3
1.1 - General precautions	
1.2 - Safety equipment	
1.3 - Machine description	
1.3.1 - General description	
1.3.2 - Construction features	
1.4 - Intended use	
1.5 - Improper use	
1.6 - Technical data	
1.7 - Structure of the machine	
PARTE 2 - TECHNICAL DATA	6
2.1 - Overall dimensions, weight, specifications	
PARTE 3 - DELIVERY	7
3.1 - Shipping (See Fig. 4(c) and (d))	
3.2 - Checks on delivery	
3.3 - Disposing of packaging	
PARTE 4 - INSTALLATION	8
4.1 - Positioning	
4.2 - Connection to the power supply	
4.3 - Wiring diagram	
PARTE 5 - USE	9
5.1 - Controls	
5.2 - Operation	
PARTE 6 - CLEANING	10
6.1 - General points	
6.2 - Storage	
PARTE 7 - MAINTENANCE	10
7.1 - General points	
7.2 - Power cable	
PARTE 8 - SCRAPPING AND DISPOSAL	10
8.1 - Decommissioning	
8.2 - Disposal	
8.3 - WEEE (Waste Electrical and Electronic Equipment) regulations	

PART 1 - INFORMATION ABOUT THE MACHINE

1.1 - General precautions

- The Ozone generator may be used only by trained staff, fully familiar with the contents of this manual.
- New staff must be trained in the use of the machine before using it.
- Strictly avoid using the appliance when other people or animals are present; ventilate the area thoroughly before allowing them to spend time in it again.
- When programming its use, concentrate on the job in hand.
- Periodically check the condition of the power cable; damaged or worn power cables pose a serious electrical hazard.
- If the machine is malfunctioning, do not use it; contact the Service Centre immediately.
- Do not attempt to make repairs yourself; always contact the "Service Centre".
- The user is not authorised to tamper with the machine in any way. Contact the "Service centre" if you encounter any anomalies.
- Any attempt to dismantle, modify or tamper with any part of the machine by the user or unauthorised personnel will immediately void the **Declaration of Conformity** drawn up pursuant to Directive 2006/42/EEC, invalidate the warranty and relieve the Manufacturer of any liability. The manufacturer is also relieved of all liability for the consequences of:
 - improper use or tampering with the machine by inadequately trained personnel;
 - the lack of or negligent maintenance;
 - the use of **non-original** spare parts and those not specified for the model in question;
 - total or partial failure to follow the instructions given in this manual;
 - the surfaces of the machine being treated with unsuitable products.

1.2 - Safety equipment

The mechanical and electrical safety equipment is conforming with Directives **2014/35**, **2006/42** and the **60335-1** standard.

The Ozone generator is therefore equipped with electrical and mechanical safety equipment both when operating and when being cleaned or serviced.

There are still "**RESIDUAL RISKS**" which cannot be completely eliminated, which are highlighted in this manual by the wording "**CAUTION**"; they are related to the risks of using it when people or animals are present, the oxidation of materials, objects and devices, its transportation, and when the machine is being cleaned and serviced.

1.3 - Machine description

1.3.1 - General description

The Ozone generator was designed and constructed by our company with the precise purpose of generating Ozone from oxygen that is normally found in the air inside premises. It is built to ensure that:

- all its parts are stable and robustly constructed;
- it is highly manageable with its handle, which makes it easy to move and transport;
- the circulation fan facilitates an excellent exchange of air/Ozone.

The models appearing in this manual are manufactured in conformity to **Directive 2006/42/EEC** and subsequent amendments.

If any accident occurs, the manufacturer shall not be held liable if the machine has been modified, tampered with, had its safety guards removed or is used for purposes other than the intended use specified by the manufacturer.

1.3.2 - Construction features

The Ozone generator:

- O₃ Port is made of anodised aluminium and AISI 304 stainless steel;
- O₃ Tower is made of AISI 304 stainless steel, materials which ensure excellent resistance against oxidation;
- Handle in ABS for easy transportation;
- The internal generator consists of a single-piece unit which raises the voltage to about 2400 V and via ceramic plates, due to the corona effect created by the strong electric field, it generates Ozone (O₃).
- Control device that can be programmed from 2 to 60 minutes with immediate start when set to ON.

1.4 - Intended use

The O₃ generator is designed to generate Ozone (O₃) and to introduce it into small to medium-sized home and business settings (maximum 100 sq.m., 300 m³ H. 3 m for each device, regardless of the declared O₃ production capacity).

It is an accessory and cannot be used as a substitute for correct and careful cleaning of rooms, objects and surfaces.

1.5 - Improper use

The machine must only be used for its intended purposes; in particular:

- It has **not** been designed for specific use in healthcare facilities and IS NOT A MEDICAL DEVICE.
- **Do not** use it to sanitise water or liquids.
- **Do not** use the equipment as a machine designed to produce Ozone intended for other purposes.
- **Do not** use the device unless it has been properly positioned with all its guards in good working order, to prevent the risk of serious injury.
- **Do not** access machine parts: **you risk getting an electric shock.**
- **Do not** start the machine if it clearly or presumably has a fault.
- Before using the machine, make sure that any potentially hazardous conditions have been adequately eliminated. If you notice anything unusual in its operation, shut down the machine and inform the "service centre".
- **Do not** allow unauthorised persons to intervene on the machine.

1.6 - Technical data

Giving precise details of the "**Model**" and "**Serial No.**" of the equipment will allow our technical service staff to provide you with a more rapid and effective response.

We recommend that you indicate the model of the machine and its serial number whenever you contact the technical assistance service.

This information is given on the nameplate shown in *Fig. 1*.

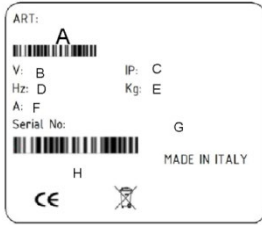

Fig. 1

- A = Model
- B = voltage
- C = IP protection class
- D = frequency
- E = machine weight
- F = Amperes
- G = Serial No

1.7 - Structure of the machine

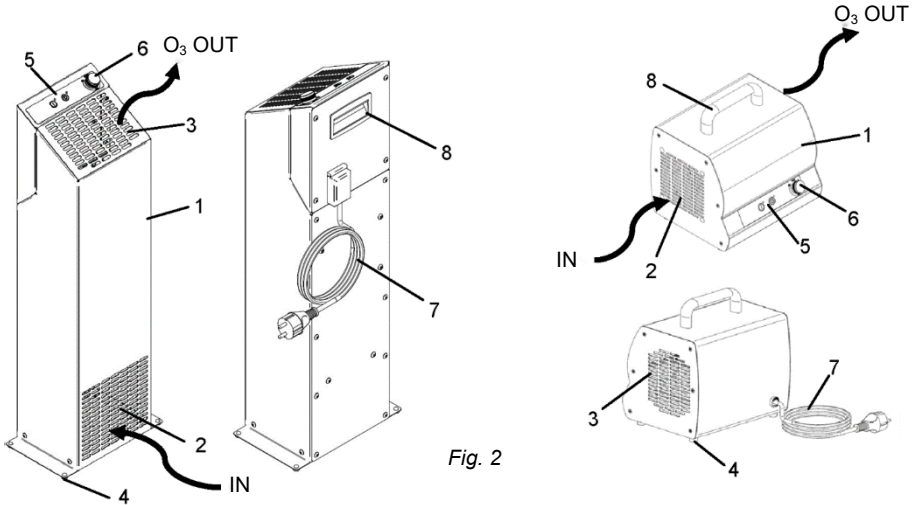

Fig. 2

LEGEND	
1	Frame
2	Suction (IN)
3	Emission (O ₃ OUT)
4	Feet
5	ON-OFF controls
6	Timer
7	Power cable
8	Handle

THE MACHINE'S ELECTRICAL SPECIFICATIONS ARE MARKED ON THE NAMEPLATE ON THE REAR OF THE MACHINE; BEFORE CONNECTING THE MACHINE TO THE POWER SUPPLY, REFER TO THE SECTION "CONNECTION TO THE POWER SUPPLY"

PART 2 - TECHNICAL DATA

2.1 - Overall dimensions, weight, specifications

Fig. 3 - Dimensions and clearances

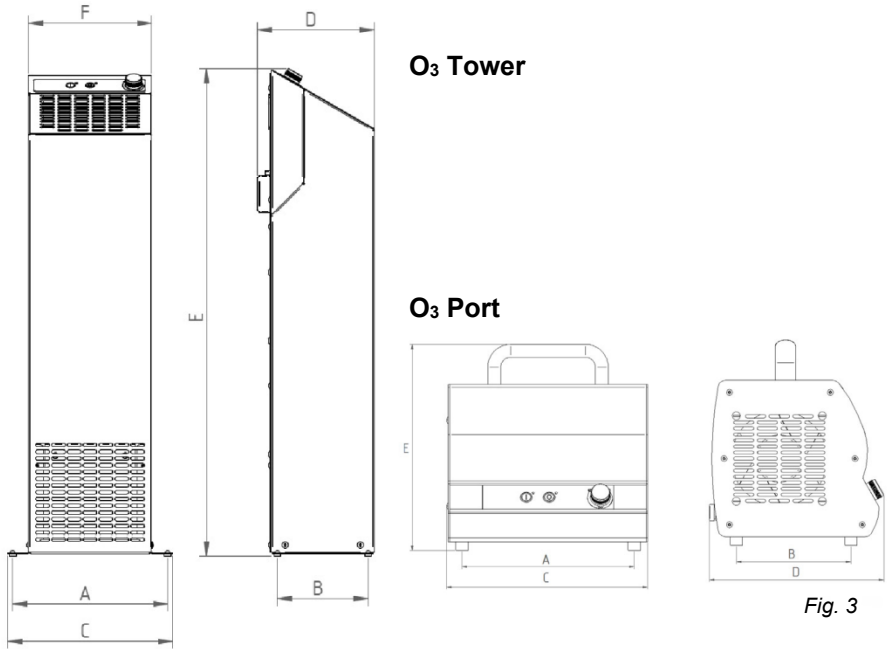

Fig. 3

Model	Units	O3 Tower 10	O3 Tower 28	O3 Tower 56	O3 Port 10	O3 Port 28
Power	W	100	200	370	100	200
Power supply		220-240V / 50 Hz				
O3 Production	g/h	10	28	56	10	28
A x B	mm	220x128,5	222x128.5	222x128.5	210x140	210x140
C x D	mm	236x166	236x166	236x166	244x210	244x210
E	mm	689	689	689	252	252
F	mm	176	176	176	/	/
Net weight	kg	6.5	6.5	7	3.7	4.2

PART 3 - DELIVERY

3.1 - Shipping (See Fig. 4(c) and (d))

The machines are carefully packed before shipping. The packaging consists of:

- robust external cardboard box (Ref. to Fig. 4) and cardboard and polystyrene or polyurethane foam internal supports;
- the machine (Ref. b or Ref. c Fig. 4);
- this manual (Ref. d Fig. 4).

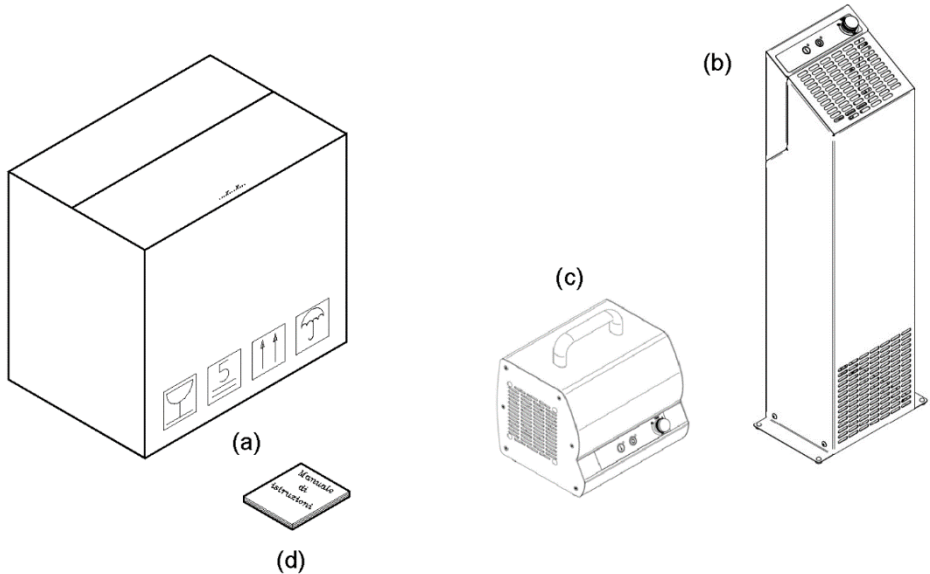

Fig. 4

3.2 - Checks on delivery

When you receive the package containing the equipment, carefully check the packaging for signs of damage during shipping.

If the packaging shows signs of mishandling, impacts or dropping, report the damage to the shipping agent within three days of the date of delivery indicated on the documents and draw up a detailed report on any damage to the machine.

3.3 - Disposing of packaging

The packaging materials (cardboard box, plastic strap and polyurethane foam) can be disposed of as normal domestic waste; there is no difficulty in disposing of them.

If the machine is installed in a country where special regulations apply, dispose of the material in line with these provisions.

PART 4 – INSTALLATION

4.1 - Positioning

O3 Port: place the appliance at a medium height (about 1 m), on a smooth, stable, fire-retardant and sufficiently wide surface.

O3 Tower: place it on the ground. Both items must be placed away from walls, furniture, furnishings and more generally away from anything that might impede the correct flow of the air intake and of the ozone O₃ emission (See Fig. 2). Place the generator in such a way that the ozone emitted flow is directed towards the open space to be treated, and never towards people and/or animals (Fig. 5).

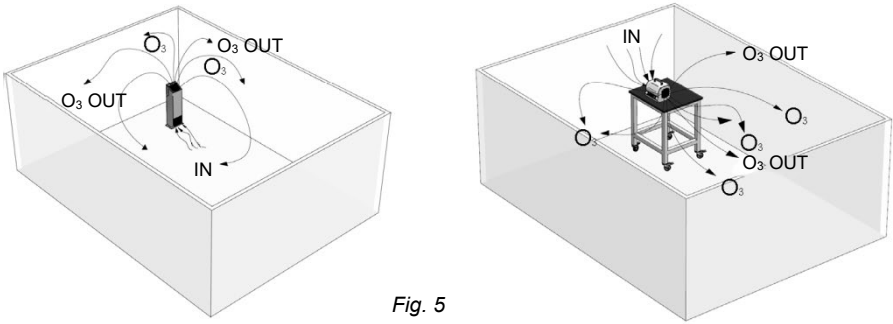

Fig. 5

4.2 - Connection to the power supply

The equipment has a power cable with a cross section of 3x1.5 mm², a length of 1.5 m and a Schuko plug. Connect the equipment to the 220-240 volts, 50 Hz power supply, paying attention that the system complies perfectly with standards with a 0.03A differential and a 10 A current circuit breaker.

Also check that the information on the machine nameplate matches the specifications given in the delivery and shipping documents, and that both the master switch and socket are easily accessible while the machine is in use.

4.3 - Wiring diagram

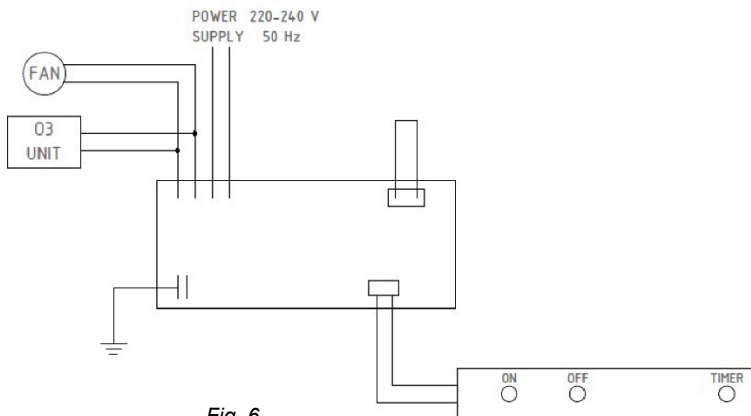

Fig. 6

PART 5 - USE

5.1 - Controls

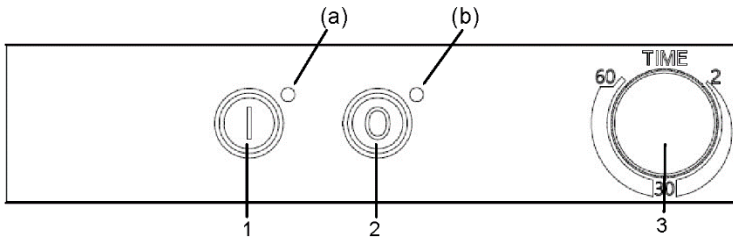

Fig. 7

START button (Ref. 1 Fig. 7): press to start the work cycle.

OFF button (Ref. 2 Fig. 7): press to stop the work cycle.

TIMER (Ref. 3 Fig. 7): this allows the user to regulate the operation from 2 to 60 minutes **LED (a)**: located next to the ON button indicates that the device is working.

LED (b): located next to the OFF button indicates that there is a power supply.

5.2 - Operation

WARNING!

Make sure that there are no people or animals in the space (it is preferable to use the device at night, for example, at the end of the working day). Check and ensure that no people enter the area over the subsequent 6 hours (e.g. cleaners, security staff, etc.) and prepare internal protocols and adequate information (e.g. warning and danger signs, etc.).

Ozone has a high oxidising power, so it is useful for eradicating germs, bacteria and mould and passivating viral loads on surfaces, objects and in the air.

In order to sanitise rooms correctly, program the device so as to ensure an output of 1 g/h of ozone for every 10 m³. The production capacity of the device is available in the technical data table and the production is expressed in g/h (grams per hour). Then set the operating time and start the ozone generator as shown in section 5.1. Leave the room, adopting the procedures to prevent other people from entering the area.

After completing the set time, the device will switch itself off automatically.

All the devices we produce are suitable for use in small and medium-sized open plan spaces (up to 100 sq.m., 300 m³, max. height 3 m)

Ozone will tend to dissipate naturally. We recommend, however, that people should re-enter the area at least 6 hours after the end of the cycle, ventilating it thoroughly and leaving the area for at least a further 15 minutes to allow a total change of air, before the area is used again permanently.

Remove the plug from the mains supply socket and put the device in a place where only the person responsible for its use has access.

WARNING!

Ozone has a strong oxidising effect that is hazardous to health.

Prolonged exposure to ozone causes oxidation and therefore ageing of surfaces and materials (in particular plastic or rubber materials, non-treated steels, etc.) or electrical or electronic equipment.

PART 6 - CLEANING

WARNING! Before cleaning the machine, remove the plug from the power socket to isolate the machine completely from the rest of the system.

6.1 - General points

- The device does not require ordinary cleaning.
- On a regular basis, check that moisture and air impurities have not obstructed the input or output grilles.
- Visually check to see that no obstructions have been caused inside the machine by dust, spiders' webs etc.
- If there is any small build-up of dust, take care to remove it. Do not use pressurised water cleaners, jets of water or detergents to clean the machine.
- Do not use tools, brushes or anything that may damage the machine's surfaces.
- Do not clean any part of the machine in a dishwasher.

6.2 - Storage

To protect against dust build-up, we recommend that the device is stored in a dry and dust-free place (for example, in its original packaging, in a cupboard, etc.).

PART 7 – MAINTENANCE

7.1 - General points

Before performing any maintenance on the machine, **the plug must be removed from the mains power socket to isolate the machine completely from the rest of the system. For any maintenance requirements, contact the “SERVICE CENTRE”.**

7.2 - Power cable

Check the condition of the cable regularly and call the SERVICE CENTRE if it needs replacing.

PART 8 - SCRAPPING AND DISPOSAL

8.1 - Decommissioning

If you decide to put the machine out of service for any reason, make sure that it cannot be used by other persons: **disconnect and cut the electrical connections.**

8.2 - Disposal

Once the machine has been decommissioned, it can be easily sent for disposal. This should be done by a waste management company, and its materials sorted for disposal.

8.3 - WEEE (Waste Electrical and Electronic Equipment) regulations



Pursuant to Art. 13 of Italian Legislative Decree No. 151 of 25 July 2005 “Implementation of Directives 2002/95/EC, 2002/96/EC and 2003/108/EC relating to the reduced use of hazardous substances in electrical and electronic devices, and to waste disposal”.

The rubbish bin symbol on the machine or on its package indicates that the product must be disposed of separately from other waste, at the end of its useful life.

The recycling waste collection of this machine is organised and managed by the manufacturer. If the user wishes to dispose of this machine, they must contact the manufacturer and follow the given instructions to make sure the recycling waste collection procedure is followed at the end of the machine's useful life.

The correct disposal of the machine for subsequent recycling, management and treatment of its parts in an environmentally-friendly way contributes towards avoiding any possible adverse effects on the environment and promotes the reuse and/or recycling of the machine materials.

Unlawful disposal of the product by the user will lead to the application of administrative penalties under current law.

***SERVICE CENTRE
AUTHORISED RETAILER***