



**Model**

MP9

**Product Description**

Planetary Mixer, 9 litre, Heavy Duty

**Product Code**

5MP9

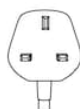

**Standard Features**

- Heavy duty 9ltr, counter-top, planetary mixer
- Particularly suitable for bakeries, hotels, restaurants, canteens etc
- Easy to operate
- Planetary mixing action and digital timer ensures perfect results
- High torque, 650 Watts motor allows mixing of stiffer doughs and larger batches
- Automatic electronic 10-speed control and digital timer
- 10 Variable speeds from 181 rpm to 561 rpm
- Non-stop shifting speed
- Interlocking bowl guard and bowl lift
- Perspex safety guard with ingredient chute and automatic shut-off when guard is opened at any speed
- Overload protection (NVR device)
- Long lasting lubricant providing abrasion resistant transmission
- Transmission gears are made of heat treated, hardened steel
- All metal and die-cast aluminium body
- Quiet operation

**Standard Accessories / Attachments**

- 1 x Whisk
- 1 x Beater
- 1 x Dough Hook
- 1 x 9 litre stainless steel bowl

**Warranty**

Covered by Metcalfe 3-year warranty (1<sup>st</sup> year parts and labour, 2<sup>nd</sup> & 3<sup>rd</sup> years parts only) and full after sales service

**Optional Accessories / Attachments**

Item	Product Code
Bowl	MPD10-12-001
Beater	MPD10-12-002

Item	Product Code
Dough Hook	MPD10-12-003
Whisk	MPD10-12-004

## Drawing

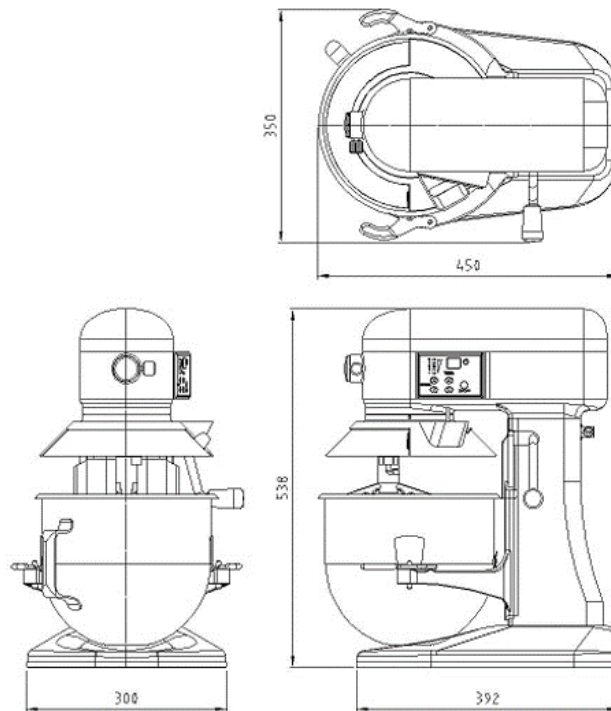

## Specifications

Model	Capacity (ltr)	Phase (Ø)	Motor (Volt)	Frequency (Hz)	Power (kW) / (hp)	Speed (rpm)
MP9	9	1	220-240	50	0.65 / 0.87	181-561

## Dimensions | Shipping Information

Model	Overall Dimensions D x W x H (mm)	Net Weight (kg)	Packed Dimensions D x W x H (mm)	Packed Weight (kg)	Volume (m3)
MP9	450 x 350 x 538	20	540 x 420 x 640	22	0.145

We reserve the right to alter the specification and technical details for this item at any time without prior notice. 08/2021

## Metcalfe Catering Equipment Ltd

Haygarth Park  
Blaenau Ffestiniog  
Gwynedd, LL41 3PF

